



REVALVE

BY PKTBA SINCE 1962

TECHNICAL SPECIFICATION LAPPING & GRINDING EQUIPMENT

Models: PKTBA-SPSH-600N
DN 50 – 600 (NPS 2 - 24)

P.O. 440060 Russian Federation, Penza, Prospect Pobedy, 75
www.revalve.com Tel./fax: +7 (8412) 200-201
e-mail: sales@revalve.com



Grinding & Lapping equipment

Machine for grinding & lapping of pipeline valves PKTBA-SPSH-600N

1	Name	Machine for grinding and lapping of pipeline valves PKTBA-SPSH-600N
---	------	--



2	Purpose	The machine is designed for grinding and lapping of the flat sealing surfaces of the gate valves body's and wedges, globe valves body's and disks, safety valves parts and other flat surfaces.
3	Description	<p>The machine consists of the following main elements: basement, inclining table, rotation device, column assembled with carriage, control panel, electric cabinet and tool cabinet</p> <p>Carriage height, spindle rotation speed and machining timer are adjusted from the control panel which is mounted on rotating height-adjustable bar.</p> <p>Inclined table angle and column rotation angle are adjusted manually.</p> <p>Emergency stop button is located on the control panel allowing an</p>

Grinding & Lapping equipment

operator to stop the machining process immediately in case of any potential hazard.

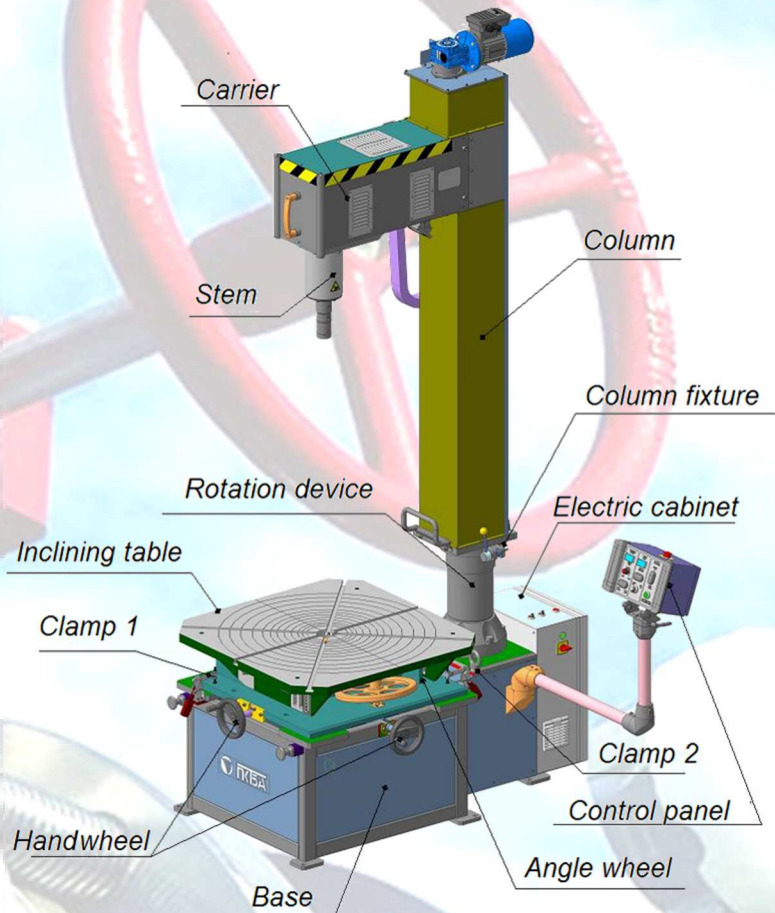

The tool cabinet serves for storage of the set of changeable parts for grinding and lapping and for storage of the set of the spare parts.



Dimensions 900 x 900 mm
Inclination angle 0 – 12°
Max table load – 2500 kg



4

Inclined tables

Grinding & Lapping equipment

5	Machine control	<p>All controls are located on control panel based on swinging arm.</p> <p>Regulators:</p> <ul style="list-style-type: none"> • spindle rotation speed, • table rotation speed, • headstock vertical travel rotation speed <p>Knobs:</p> <ul style="list-style-type: none"> • emergency stop • headstock up/down • spindle rotation start/stop • table rotation start/stop <p>Indication:</p> <ul style="list-style-type: none"> • spindle rotation speed display • table rotation speed display <p>Grinding time display installed on the control panel allows to operate grinding and lapping in time: in hours, minutes or seconds.</p>	
6	Maximum face-to-face length of the mounted valve, mm	1150	
7	Maximum diameter of the mounted valve flange, mm	890	
8	Machined surface roughness, μm	At grinding: 0,4...0,8 At lapping: 0,2...0,4	
9	Electric supply, V/Hz/kW	400 / 50 / 3	
10	Scope of supply	<p>Scope of supply includes:</p> <ul style="list-style-type: none"> - Machine for grinding and lapping of seal faces of bodies and wedges of the valves NPS 2-24" (PKTBA-SPSH-600N) <p>Set of changeable parts for lapping:</p> <ul style="list-style-type: none"> - Set of adapters for lapping - Set of laps for valves NPS 2-24" <p>Set of changeable parts for grinding:</p>	

Grinding & Lapping equipment

- Set of adapters for grinding
- Set of extenders for valves NPS 4-10"
- Set of extenders for valves NPS 8...12.8"
- Set of extenders for valves NPS 14...24"
- Set of grinding discs for valves NPS 2-24"
- Set of grinding rings



Set of changeable parts for grinding of safety valves;

- Set of adapters for lapping
- Set of laps for safety valves NPS 1-12"



Set of tools and accessories

- Tool cabinet
- Digital inclinometer
- Set of tools
- Accumulator flashlight
- Automated battery charger

Set of spare parts includes:

Waterproof adhesive grinding rings (quality: aluminum oxide)

- Ø30, grit P80
- Ø30, grit P120
- Ø30, grit P240
- Ø50, grit P80
- Ø50, grit P120
- Ø50, grit P240
- Ø80, grit P80
- Ø80, grit P120
- Ø80, grit P240

		<ul style="list-style-type: none"> - Set of adapters for grinding - Set of extenders for valves NPS 4-10" - Set of extenders for valves NPS 8...12.8" - Set of extenders for valves NPS 14...24" - Set of grinding discs for valves NPS 2-24" - Set of grinding rings <p>Set of changeable parts for grinding of safety valves;</p> <ul style="list-style-type: none"> - Set of adapters for lapping - Set of laps for safety valves NPS 1-12" <p>Set of tools and accessories</p> <ul style="list-style-type: none"> - Tool cabinet - Digital inclinometer - Set of tools - Accumulator flashlight - Automated battery charger <p>Set of spare parts includes:</p> <p>Waterproof adhesive grinding rings (quality: aluminum oxide)</p> <ul style="list-style-type: none"> - Ø30, grit P80 - Ø30, grit P120 - Ø30, grit P240 - Ø50, grit P80 - Ø50, grit P120 - Ø50, grit P240 - Ø80, grit P80 - Ø80, grit P120 - Ø80, grit P240
11	Overall dimensions (LxWxH), mm, not exceeding	1630 x 1640 x 3130 – the machine 1025 x 625 x 2000 – the tool cabinet
12	Weight, kg, not exceeding	1350

Grinding & Lapping equipment

13

Installation layout

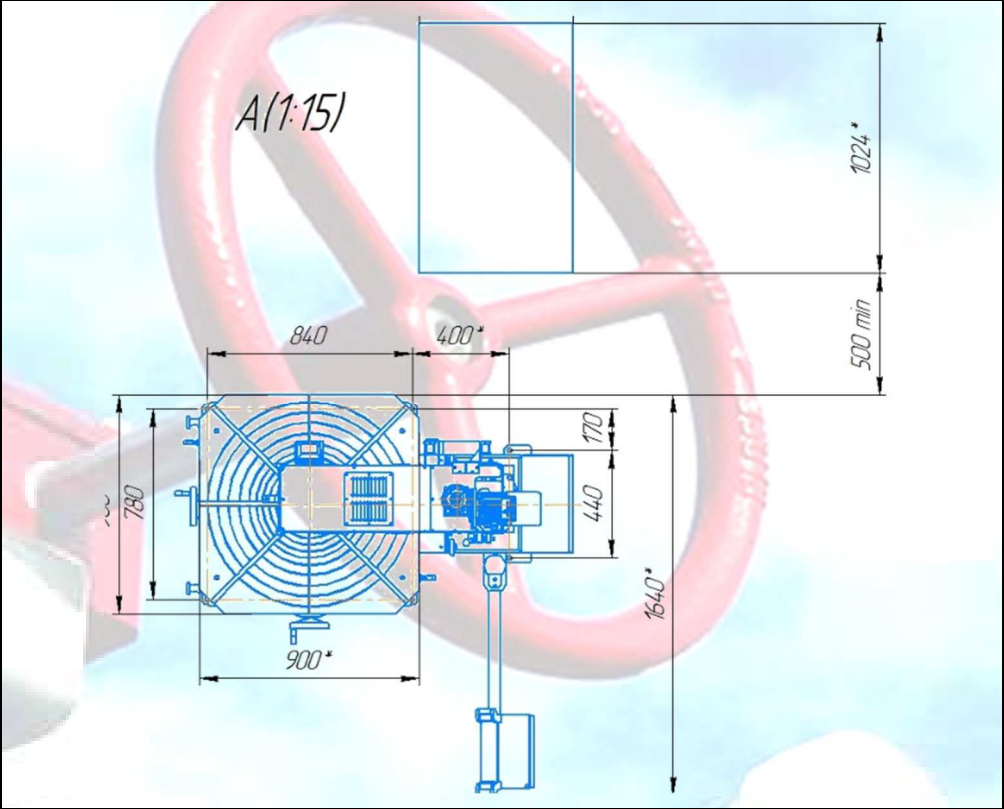

Grinding & Lapping equipment

GENERAL REQUIREMENTS

1	Requirements for ergonomics	<p>The design of the equipment should ensure free access to equipment for maintenance and repair.</p> <p>Where necessary, the design of the equipment must be capable of performing the convenience of the labor action with means of individual protection.</p> <p>The design of the equipment should provide the optimum distribution of functions between man and production equipment to ensure the safety and to limit severity and intensity of labor.</p>
2	Safety requirements	<p>The equipment complies with European union technical regulation “On safety of machines and equipment” Directive 2006/42 CE;</p> <p>The equipment complies with European union technical regulation “On safety of low voltage equipment” Directive 2014/35 CE.</p>
3	Reliability requirements	<p>The warranty period of equipment - 12 months from the date of commissioning or 18 months from the date of dispatch whatever is earlier.</p> <p>The total period of operation, taking into account proper service and the replacement of worn units - at least 8 years.</p>
4	Information plate language	Russian/English
5	Operating conditions	<p>Temperature: +5-50 °C</p> <p>Humidity (at + 25°C): 30-90% (non condensing).</p> <p>Indoor use under the following conditions:</p> <ul style="list-style-type: none"> • work site should be equipped with a ventilation system; • height above the mean sea level – not exceeding 1000 m; • no shock allowed. <p>The use in conditions of the explosive and electric current conducting mediums or mediums, containing caustic vapors and gases is not allowed.</p>

DOCUMENTATION

1	Each unit	<p>Passport / Technical certificate (including test and calibration certificates for all installed test pressure gauges and sensors)</p> <p>Operation / Maintenance Manuals</p> <p>CE Declaration</p>
---	-----------	---

Attention! Dimensions are provided for the reference and could be a subject for amendment during the design phase without changes in the complex performance parameters.

Attention! This is a preliminary version. The set of equipment or it's specification can be altered upon request to meet customer's requirements.

Grinding & Lapping equipment

Spare parts, consumables, additional services:

1. Set of spare parts and consumables for 2 years of operation.

Set of spare parts includes all necessary consumables for two years of normal operation of the equipment. Spare parts kit is included to the scope of supply and will be supplied along with equipment.

2. Factory acceptance, testing and supervision during installation and start-up. Training on customer site. Warranty and after sales service.

In accordance with internal QMS system (certified and based on ISO 9001-2015 requirements), our Quality Department will provide FAT program and corresponding agenda upon customer's request for participation in factory acceptance testing of the manufactured equipment before it's dispatch.

All the equipment stated above is certified in accordance with EN 60204-1, EN ISO12100:2010, EN 2006/42/EC, EN 2014/35/EC requirements, supplied with the EU Declaration of Conformity and has the CE Marking.

Upon request, qualified and experienced engineers of REVALVE can perform control over the installation and commissioning of the equipment.

Installation period should begin only after receiving the following confirmation:

- All the equipment is received at the installation site;
- All the installation requirements (procedures, equipment, accessories, qualified personnel etc.) are fulfilled (the list of requirements will be prepared in advance by REVALVE service team).

Under request, our qualified engineers can:

- Supervise the installation of the equipment and its launch;
- Perform the final preparation of the equipment assisting customer personnel.

Personnel training on customer's site:

We assign the utmost value to appropriate customer personnel user-training to ensure safe and efficient running and maintenance of the equipment. We consider that personnel user-training is sufficiently required, especially in cases where the personnel have no experience operating our precise equipment.

The proper study of equipment design features, safe operation requirements and maintenance methods increases the performance of the equipment, and prolongs its service life.

Training can be conducted both in Russian and in English languages.

The expected time period required for start-up supervision, commissioning and training will be determined in a due time upon request.

Warranty and after sales service.

REVALVE provides 18-month warranty after the equipment dispatch and 12-month warranty after the launch date of the equipment at customer site or 18 months since the date of dispatch. The assumed service life of our equipment is 8 years, at least.

REVALVE is a customer-centric company and our assistance policy is based on a long-term partnership with our customers.

We have a full-cycle in-house manufacturing:

- Designing.
- Raw materials preparation treatment;
- All types of machining procedures using high-duty CNC centers (our production facilities;
- account more than 200 machining units);

Grinding & Lapping equipment

- Spare parts supplied by the approved world-famous manufacturers;
- Full-cycle paint coating;
- Assembling and testing of manufactured equipment with load 1,5 times exceeding nominal;
- Installation and start-up supervision;
- Comprehensive user-training.

Our customer-centric approach to the support policy ensures a due time spare parts supply and support through all service life of the products.